



Assessing the Impact of European Initiatives on Mitigating Severe Climate Effects in Egaleo: A Technological and Social Innovation Perspective

Vasileios-Alexandros Rafail¹, Ioannis Zarikos², Stelios Karozis², Athanasios Sfetsos², and Dimitrios Tzempelikos¹

¹Department of Planning, Development & Transparency, Municipality of Egaleo, Greece

² Environmental Research Laboratory, Institute of Nuclear & Radiology Sciences & Technology, Energy & Safety, National Centre for Scientific Research “DEMOKRITOS,” Athens, Greece
ts@ipta.demokritos.gr; i.zarikos@ipta.demokritos.gr

Keywords	Climate change, risks, vulnerable groups, transformational adaptation, awareness
City Population	65,831
City Area	6,450 km ²
GDP City	12,234 USD
Climate Zone	Csa (hot-summer Mediterranean)
ARC3.3 Linkage	Governance, Enabling Policy Environments, and Just Transitions

Introduction. The Municipality of Egaleo (EGL) is located in the west region of Attica, with a population of 65,831 inhabitants according to the 2021 census. However, it is estimated that the city is inhabited by approximately 120,000 people and the average neat density is 225 inhabitants/hectare. Egaleo is one of the oldest municipalities of the country and has always been a pole of attraction for new settlers. Egaleo’s high citizen density, along with the ever-present events of climate change, has brought forth several pressing issues. Among these issues are the drastic increase of vulnerable groups, accompanied by severe weather, leading to a general lack of preparedness for climate disasters. Egaleo is experiencing citizen unemployment rates reaching up to 30%, one of the highest in the country, and an increase of elderly citizens and beneficiaries of the Social Market.

Simultaneously, Egaleo is prone to future floods from Kifisos river, while also presenting increased risk of high temperatures during the warmer seasons which further deteriorates its high social vulnerability (Krommyda, 2016). Further proliferation of the citizens’ vulnerability, in conjunction with climate change, inevitably leads to the systemic degradation of Egaleo, which will impact the whole region of Western Athens. The need for transforming Egaleo into a climate neutral and inclusive city have been marked from its larger scale published Studies: Sustainable Energy and Climate Action Plan (SECAP, 2021) and the Sustainable Urban Mobility Plan (SUMP, 2021). SECAP’s examination of Egaleo’s resources

have highlighted Water Resources and Management, Public Health, and Energy as the most vulnerable priority sectors. SUMP highlights the increased usage of cars within the city that has worsened the city’s air pollution, as well as in the mobility limitations of people with motor disabilities.

The main conflict that Egaleo must constantly overcome is its internal, bureaucratic procedures that hinder its decision making, time management and overall efficiency as a solution provider. Difficulties in policy making, made worse by overly complex and time-consuming rules, as well as the restricted use of and adherence to the established public input and collaborative planning mechanisms within EU funding by national authorities and stakeholders, result in a lack of effective inclusion of the needs of beneficiaries, citizens, businesses, and stakeholders in the policies and actions that are put into effect (ECA, 2017).

Brief History. The aforementioned socio-ecological problems in Egaleo began to emerge from the period it was densely occupied en masse between 1922 – 1928. Ever since, it became a popular work settlement, especially for workers during the 1980s due to the operation of the gunpowder factory “Baroutadiko” in the city. Despite the overall slight decrease of the population (2011 census: 69,946 vs. 2021 census: 65,831), the city remains heavily congested, resulting from its many industrial infrastructural remnants that are not suited for living. The population’s congestion, along with the large volumes of daily visitors due to Egaleo’s commercial presence, initiated a cluster of environmental problems.

Another detrimental issue defined in Egaleo is the increase in the intensity of weather events, due to climate change. Climatic simulations indicate the appearance of high intensity storms in Egaleo, generating very large volumes of runoff and increasing the likelihood of flooding. Additionally, the likelihood of flooding is affected by other non-climatic factors such as residential development and the proper functioning of the storm-water drainage system. The risk of fires is also ever-present in Egaleo, being home to the largest green space in Western Athens (Baroutadiko Grove). The overall dry climate of the Attica Region, in conjunction with the increased temperatures and inhabitants’ general behavior (lack of civic mindset, attempted arson), regard Egaleo as highly prone to fire incidents. SUMP adds to these issues by exposing the weaknesses of Egaleo’s urban planning. An uneven distribution of public spaces and green areas, accompanied by the presence of many major roads (Iera Odos Av., Thivon Av.) and the dysfunction of sectional

footpaths and cycle paths, further contributes to Egaleo’s environmental decline. An analysis of SUMP also revealed that resources from European-funded projects are a highly feasible opportunity to deal with the city’s degrading micro-climate, as it also emphasizes the lack of national resources.

Analysis, Evaluation, and Implementation. EGL, being part of the Western Region of Attika in Greece, belongs to the wider Mediterranean biogeographical region. As thoroughly assessed earlier on, Egaleo is at great risk of drought and wildfires in the “Baroutadiko Grove”. Furthermore, heatwaves (Figure 1) also pose a direct heat stress danger to elder citizens and to households that cannot afford adequate cooling, which also puts a strain on energy demands such as cooling. Among the major natural risks that are threatening Egaleo are fires caused by the severe temperatures and the dryness of the vegetation during summertime.

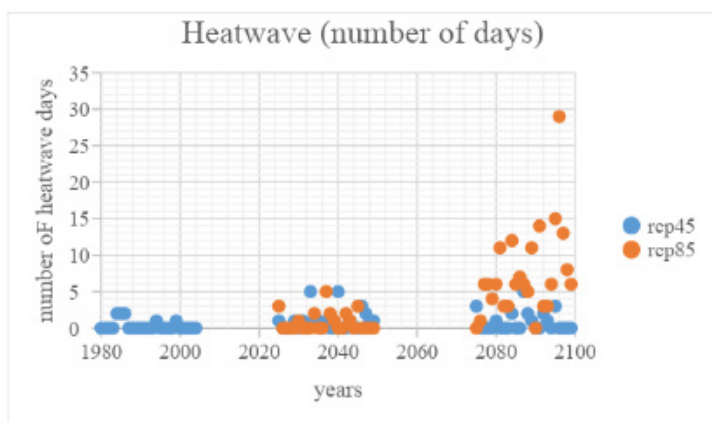

Figure 1: Comparison of heatwave duration (in days with minimum temperature $\geq 26^{\circ}\text{C}$ and maximum temperature $\geq 39^{\circ}\text{C}$) between historical period (1980-2004), near future (2025-2049), and far future (2075-2099) under RCP4.5 and RCP8.5 scenarios.

Another potential natural risk for Egaleo is flooding from urban flash floods, which is due to the insufficient flood risk management systems. Egaleo is located near Kifissos river, which has a high risk of flooding during the mid-autumn-winter session, causing massive damage to the area.

There has been a series of wildfires roaming throughout summertime in Greece. Egaleo has not experienced a direct episode of fire in Baroutadiko Grove, although each summer temperatures have been reaching up to 45°C , putting the municipality in an alarming state. Stoyanous and Bilinis (2016) presented the issues that Egaleo is facing, increasing the territory’s vulnerability from a climate perspective, including:

- The slow population growth rate, high unemployment rate and the prevalence of vulnerable groups (unemployed and elderly citizens, migrants, offenders). These groups often lack the resources to protect themselves against severe climate effects, and the slower economic growth of Egaleo makes it difficult to keep up with their support.

- Issues related to the infrastructure, mostly the inefficient street planning, and the lack of public spaces and parking lots. That leads to surplus people activity in public spaces and increased traffic volume that can cause amplified harm to the environment of the area.
- Direct environmental issues that are caused by the industrial activity in Eleonas and Yula areas. The increasing temperature in Egaleo during summertime is evidence for its citizens to realize the existence of climate change. This could urge them to become more aware about their living habits and start changing their lifestyle to become more eco-friendly (e.g., start using public transportation more, reduce in-house electricity usage, not litter the streets).

Currently Implemented Socio-technical Innovations.

Egaleo has been able to facilitate impactful, multispectral solutions for the aforementioned socio-environmental issues due to its active presence in the field of European-funded Sustainability Projects. These Projects are of great importance for Egaleo, as they foster international cooperation to exchange knowledge for resolving dire issues, as well as highlighting the importance of civic participation in all citizens. As the Municipality successfully implements many different projects from various strands (HORIZON 2020/EU, EUI-IA, ERASMUS+), this case study will present the actions carried out in The TransformAr project (H2020-CP-IA-2017, GA: 101036683).

The TransformAr project aims to develop and demonstrate products and services to launch and accelerate large-scale and disruptive adaptive processes for transformational adaptation in vulnerable regions and communities across Europe. In the context of TransformAr, EGL will build a series of complementary solutions to increase climate awareness and adaptation of EGL and its citizens. EGL solutions consist of data collection from various sources, analysis and post-processing of the data promote climate awareness and/or utilize them for evidence-informed climate adaptation policy suggestions at local municipality levels.

Table 1 on the following page presents each solution for EGL carried out in the European Union-funded TransformAr project.

Solution	Description
Smart Climate Station - SCS	EGL focuses on the installation of 21 Smart Climate Stations (SCS) around key areas of the city. The purpose of the SCSs is to gather real-time data regarding the micro-climate of the city, supporting the public administration office to ready the citizens in case of climate emergencies. After careful consideration and design, the key areas have been identified and the SCSs will begin their operation during the timeline of this demo. SCS will register Temperature, Relative Humidity, Atmospheric Pressure, CO ₂ (ppm), PM 2.5 /10 (ppm), Wind speed and Rainfall.
Demand Social Analysis - DSI	EGL provides a series of social/health services to its citizens. Due to climate change impacts, the demand for such services is expected to change. To prepare to supply the services without interruption and meet the future demand, a demand analysis for social services/infrastructures will be performed. The analysis will provide the data to plan an adaptation strategy by taking into account the supply and demand of social services of the future.
Citizen App – CAE	EGL will develop a mobile app for gathering and distributing information; (1) it will use crowdsource data about climate awareness of citizens of EGL via a questionnaire, (2) disseminate TransformAr’s EGL solution to the public and (3) to provide notifications for climate related events.
Awareness module - AWAR	EGL will develop and test a curriculum for pupils between 16-18 years old related to climate change understanding and climate awareness.
Climate Innovation Hub - CIH	EGL will upgrade a multi-purpose facility to Climate Innovation Hub by (a) create a permanent exhibition about climate change and TransformAr solutions of EGL, (b) conduct a live demonstration of the data streaming from SCS and the post-processing indicators, and (c) organize a series of events for promoting climate innovation (e.g., datathons), thus, providing access to the EGL’s data and asking for innovative solutions for EGL’s climate related problems.

Table 1: *Description of EGL solutions from the TransformAr Project*

Weather and environmental data are operated by the National Centre for Scientific Research “Demokritos” (NCSR-D), to be fused with daily weather forecasts and produce a high-resolution weather forecast for the region of EGL. In addition, NCSR-D will provide the data management techniques to clean, process and visualize the environmental data. DSI analysis will utilize the infrastructure and data services of EGL and the statistical methods of NCSR-D in order to take the results of the E3M socio-economic model and downscale the information to the municipality level.

The post-processed information, alongside the results of crowdsourced data (questionnaires) and demand analysis will be disseminated via CAE directly to EGL citizens. Part of the information will be used in the climate awareness curriculum for pupils (AWAR) and the EGL TransformAr dataset will be made available in CIH alongside the permanent climate exhibition and live data streaming. Figure 2 illustrates the coupling of EGL solutions and the flow of information from data sources to communication channels.

The expected innovation of EGL’s solutions can be categorized in three groups; (a) the streaming dataset comprised of different types, formats and resolution (CAE, SCS, DSI, post-processed information), unique for a municipality, (b) the fusion and use of the data for evidence-informed policy suggestions, alongside raising awareness at the citizen (CAE, AWAR) level and promote innovation (CIH), and (c) the replicability and transferability of EGL’s ecosystem of solutions, as the main concept [Data, Analysis, Act (see Figure 1)] can be followed with different components and under the same scope.

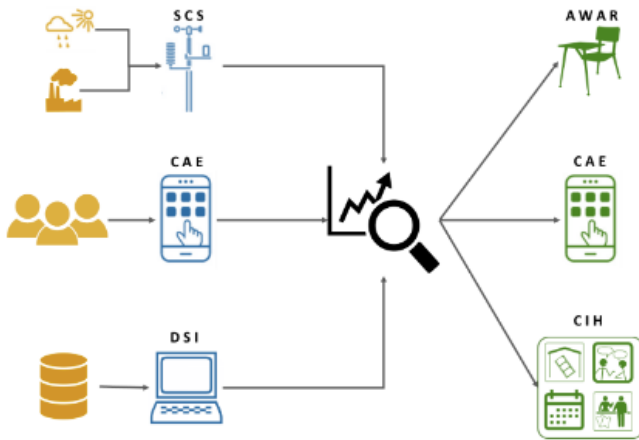

Figure 2: Illustration of EGL solutions working complementary to each other.

Future Implementation and Concluding Thoughts. The presented implementation of innovative solutions falls within a wider Sustainable Urban Development plan of EGL targeted to reduce the socio-economic impacts of a green transition in implementing a multi-dimensional approach. Embracing the national policy of carbon neutrality by 2050, EGL has set an interim goal of a 40% reduction for 2030 (SECAP 2021), which is depicted in individual municipal plans. The main interventions will be aimed towards increasing the energy efficiency of public and private buildings and GHG emissions reduction.

In the framework of the ongoing New European Bauhaus, “a creative and interdisciplinary initiative that connects the European Green Deal to our living spaces and experiences” (New European Bauhaus), Egaleo will implement energy and circularity interventions in multiple private homes to enhance their functionality. Smart sensors will be used so that the building’s resources (input, everyday equipment, waste, energy, water, etc.) will be managed circularly based on the refuse, reduce, reuse, repair, repurpose, recycle, and recovery concept.

In parallel, there are multiple activities to strengthen social cohesion, in response to negative social phenomena which are amplified by the impacts of climate adaptation. They include the upgrading of social infrastructure and promoting social integration of vulnerable and marginalized groups, and improving and providing opportunities for equal access to the labor market and entrepreneurship, especially for young people.

Finally, EGL pushes for a “smart” approach to development, through the use of the convergence of technologies and the enhancement of the digital transformation. Within this framework, the development of suitable tools and interfaces to provide enhanced service levels to citizens and the private sector are also forging an innovation ecosystem in the ICT domain.

References

- Datseri, A. (2021). *The Mobility of the First Level Local Authorities - Case Study in the Municipality of Egaleo*. [Master’s thesis, University of West Attica.] (in Greek). https://polynoe.lib.uniwa.gr/xmlui/bitstream/handle/11400/630/Datseri_1903.pdf?sequence=1&isAllowed=y
- ELSTAT (Hellenic Statistical Authority). (2021). *Population Census 2021*.
- European Union. (n.d.). *New European Bauhaus*. https://new-european-bauhaus.europa.eu/about/about-initiative_en
- European Union. (n.d.). *TransformAr*. <https://transformar.eu/>
- Government Gazette. (2006). ‘Law N.3463/2006’, Athens, Greece.
- Government Gazette. (2010). ‘Law N.3852/2010’, Athens, Greece.
- Government Gazette. (2018). ‘Law N. 4555/2018’, Athens, Greece.

Krommyda, V. and Oikonomou, D. (2016). *Planning for Climate Change in the Attica Basin*. Spatial Guidelines for Prevention and Adaptation for Western Athens. 9th Panhellenic Conference of HellasGIs (in Greek). https://www.researchgate.net/publication/311512051_SCHEDULE_ASMOS_GIA_TEN_KLIMATIKE_ALLAGE_STO_LEKANOPEDIO_AT_TIKES_CHORIKES_KATEUTHYNS_EIS_PROLEPSES_KAI_PROSARMOGES_GIA_TE_DYTIKE_ATHENA

Municipality of Egaleo. (2021). *Sustainable Energy and Climate Adaptation Plan*. https://mycovenant.eumayors.eu/storage/web/mc_covenant/documents/8/Llzq_PvrhouUxDx3S7M5_Jpi1evgVKFC.pdf (in Greek)

Municipality of Egaleo. (2021). *Sustainable Urban Mobility Plan*. Available at: <https://www.aigaleo.gr/wp-content/uploads/.pdf> (in Greek)

Acknowledgements

We would like to thank Jaad Benhallam for his valuable feedback in reviewing this case study.

Additional Data

- Population Density: 10,206 people/km² [2021]
 - Gross National Income (GNI): 22,590 USD (High Income) [2023]
 - Gini Coefficient: 32.9 [2021]
 - Human Development Index (HDI): 0.908 (Very High) [2023]
 - Type of Climate Intervention: Adaptation
-